

# COMPACT VOLT METER Installation manual

**DAYTONA**  
http://www.daytona-europe.com

## Please be sure to read before use

- DAYTONA Corporation shall not be held liable for accidents or damages that arise from a failure to observe these warnings and cautions.
- This installation manual is intended for qualified service technicians who have motorcycle basic knowledge and repair skills. Performing installation or inspection without such general knowledge and service skills may cause operation or maintenance-related problems to the motorcycle and may lead to damage to the kit and/or motorcycle.
- If you feel any abnormality when riding, immediately find a safe place to stop the motorcycle and check the problem.
- Make sure the routing of the harness does not impair the maneuverability of the motorcycle.
- Disconnect a negative terminal from battery before installing.
- This product is designed for DC12V only.
- DO NOT install with wet hand.
- DO NOT apply heavy impact.
- DO NOT disassemble or modify this product.
- DO NOT install in a place that will be high temperature.
- Be careful to keep this product away from any chemicals such as gasoline, brake fluid or solvent.
- Under the IPX7 designation, this product will be able to withstand immersion in water up to 1m for up to 30min. This means riding in the rain or washing your motorcycle will not cause damage, but splaying high pressure water (such as high pressure cleaner) would be harmful.

## Product features

Volt meter for battery voltage / ACC power voltage (range: DC7.5V-18.0V)  
White LED backlight  
Low voltage alert by Red LED backlight when less than 12V  
Waterproof (IPX7)

## Components

NO.	DESCRIPTION	Qt.
①	METER UNIT (37x25x10.8mm)	1
②	WIRING HARNESS (1500mm)	1
③	DOUBLE SIDED TAPE (30x20mm)	1
④	INSULATION DISPLACEMENT CONNECTOR	1

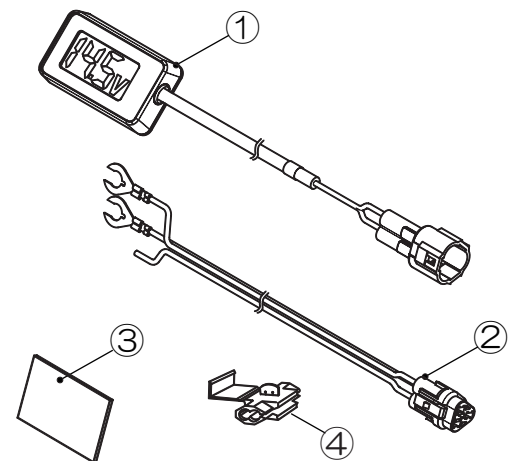

## Wiring diagrams

