

**Important:** If you are not a trained motorcycle mechanic, stop now! Ask a local motorcycle shop to do the work for you!

**Please take extra care!**

You have to mount the crash pads one side after the other!

Do not lose more than one engine mounting bolt at the same time!

For tightening torques of the engine bolts M8x25, M8x30, M10x1,25x50 and M10x1,25x65 look at the workshop manual!

Use thread locking adhesive (e. g. Loctite "low strength")!

**Fitting on the right side**

Fitting point frame/cylinder head

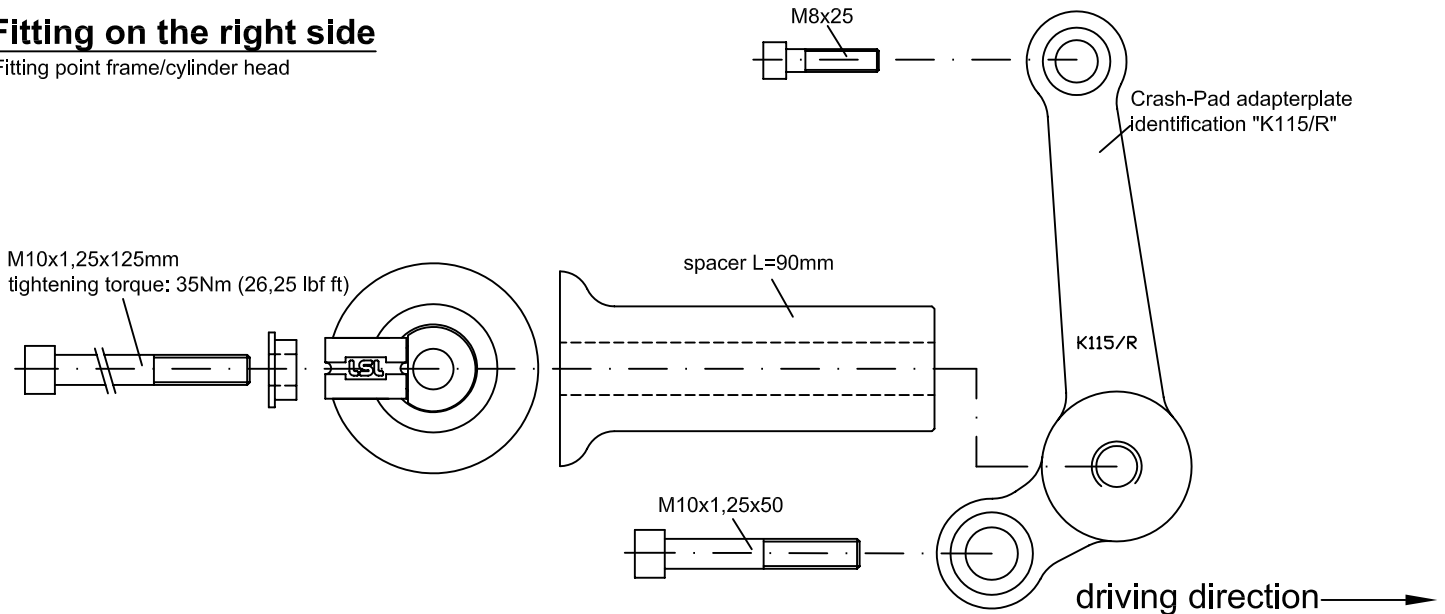

**Fitting on the left side**

Fitting point frame/cylinder head

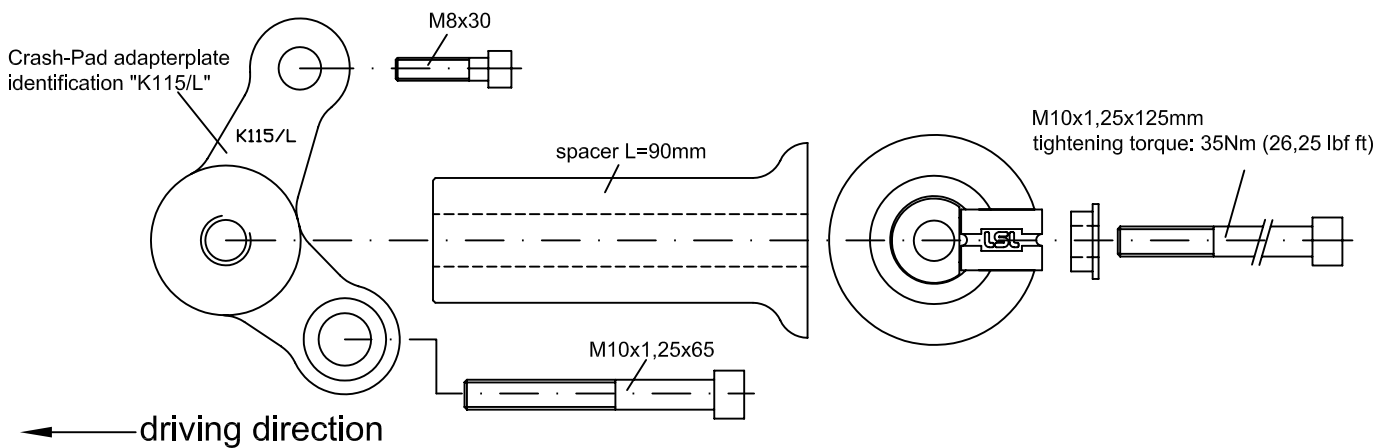

D – 47809 Krefeld

www.lsl-motorradtechnik.de

