

PIASTRA SPECIFICA - SPECIFIC PLATE
 PLATINE SPECIFIQUE - SPEZIFISCHE PLATTE - PLETINA ESPECÍFICA

GILERA RUNNER '04/'05

50/125/200cc

ISTRUZIONI DI MONTAGGIO - MOUNTING INSTRUCTIONS
 INSTRUCCIONES DE MONTAJE - BAUANLEITUNG - INSTRUCCIONES DE MONTAJE

ATTENZIONE

PESO MASSIMO SOPPORTABILE DAL PORTAPACCO 6Kg.

WARNING

MAX. LOADING OF THE CARRIER 6Kg.(13lbs)

ATTENTION

CHARGE MAXIMALE 6Kg.

ACHTUNG

MAXIMALE BELASTUNG DES TRÄGERS 6Kg.

¡ATENCIÓN!

CARGA MÁXIMA AUTORIZADA 6Kg.

A



B

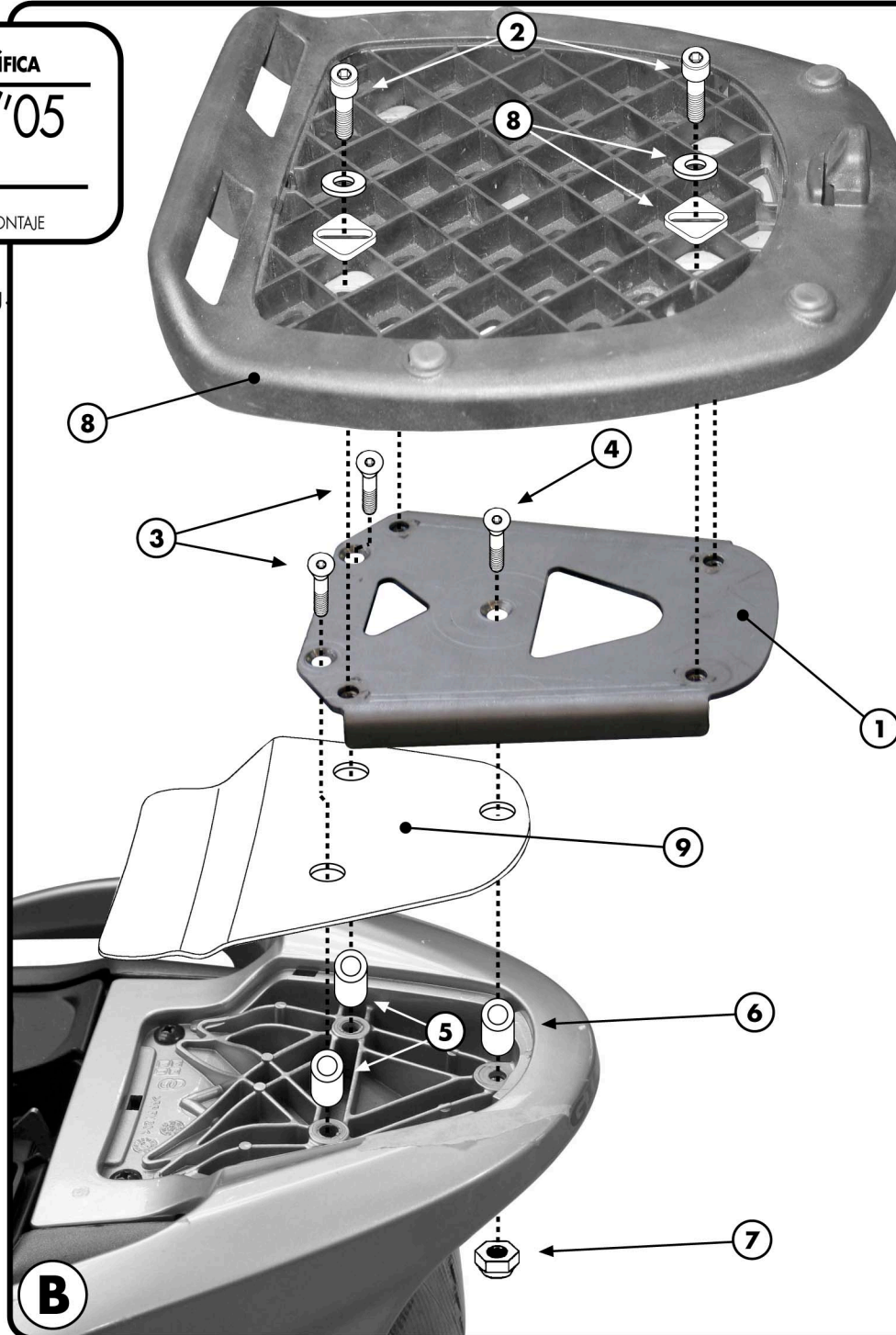

1



SUPPORTO
 SUPPORT
 SUPPORT
 HALTERUNG
 SOPORTE

Q.TY n.1

2

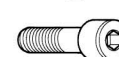

VITE TCEI M6x20mm
 SCREW M6x20mm
 VIS M6x20mm
 SCHRAUBE M6x20mm
 TORNILLO M6x20mm

Q.TY n.4

3



VITE TSCEI M6x100mm
 SCREW M6x100mm
 VIS M6x100mm
 SCHRAUBE M6x100mm
 TORNILLO M6x100mm

Q.TY n.2

4

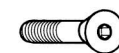

VITE TSCEI M6x50mm
 SCREW M6x50mm
 VIS M6x50mm
 SCHRAUBE M6x50mm
 TORNILLO M6x50mm

Q.TY n.1

5



DISTANZIALE Ø13x35mm
 Foro Ø7mm, V456
 SPACER
 ENTRETROISE
 DISTANZSTUECK
 DISTANCIADOR

Q.TY n.2

6



DISTANZIALE Ø15x30mm
 Foro Ø6,5mm, V454
 SPACER
 ENTRETROISE
 DISTANZSTUECK
 DISTANCIADOR

Q.TY n.1

7



DADO A.B. M6
 BOLT M6
 ECROU M6
 MUTTER M6
 TUERCA M6

Q.TY n.1

8

PARTICOLARI INCLUSI NEL KIT VITERIA DELLA PIASTRA
 COMPONENTS INCLUDED IN THE FITTING KIT OF THE PLATE
 PIÈCES INCLUES DANS LE KIT DE VIS DE LA PLATINE
 DIE EINZELNEN TEILE SIND BEI MONTAGEKIT DER PLATTE ENTHALTEN
 DESPIECES INCLUIDOS EN EL KIT DE ANCLAJES DE LA PARRILLA

Q.TY n.-

9

COMPONENTI ORIGINALI
 ORIGINAL PARTS
 PARTIES ORIGINALES
 ORIGINAL BAUTEILE
 COMPONENTES ORIGINALES

Q.TY n.-

